



Ambo IBSB Secondary School

Physics short
note

Grade 12
Unit 5

2017 E.C





Introduction:

Electronics

- ✓ the study and design of systems utilizing the flow of electrons through components like semiconductors, resistors, and capacitors.
- ✓ are integral to modern life, influencing various aspects such as communication, health, and daily tasks.
- ✓ used in common devices like calculators, digital watches, mobile phones, TVs, radios, laptops, etc.

Role in Industries:

Aerospace and Automotive: Electronics are vital in modern transportation systems, contributing to safety, efficiency, and innovation.



Medical Applications: Medical imaging tools like MRI, CT scans, and X-ray machines heavily depend on electronic technology for fast and accurate diagnostics.

Electronic Components:

- ✓ Key components include resistors, inductors, capacitors, diodes, transistors, and integrated circuits (ICs).
- ✓ Components like diodes, transistors, and ICs are made from semiconductor materials, which are essential for the functioning of electronic devices.

Note

- Electronics play an essential role in simplifying modern life and advancing key industries, particularly through the use of semiconductor-based components.



Thermionic Emission

What it is:

- Electrons within a metal gain enough energy to escape the surface when heated. This process is similar to how molecules in liquid evaporate when heated.

Key features

- ✓ negligible at low temperature
- ✓ becomes significant only at very high temperatures.

Uses

- ✓ provides a controlled supply of electrons in vacuum.
- ✓ used in a devices like cathode ray tube and oscilloscopes.



Vacuum tube devices

1. Thermionic diode:

Structure

- A vacuum tube with two electrodes:
 - ✓ **Cathode**: heated to emit electrons
 - ✓ **Anode**: at high positive voltage ($\sim + 100 V$) relative to the cathode.

Working:

- ✓ The cathode emits electrons via thermionic emission.
- ✓ These electrons are attracted to the anode, completing the circuit
- ✓ Allows current flow in one direction (rectification).

Application: converts AC to DC.

Limitation: requires a heater, which wastes power.

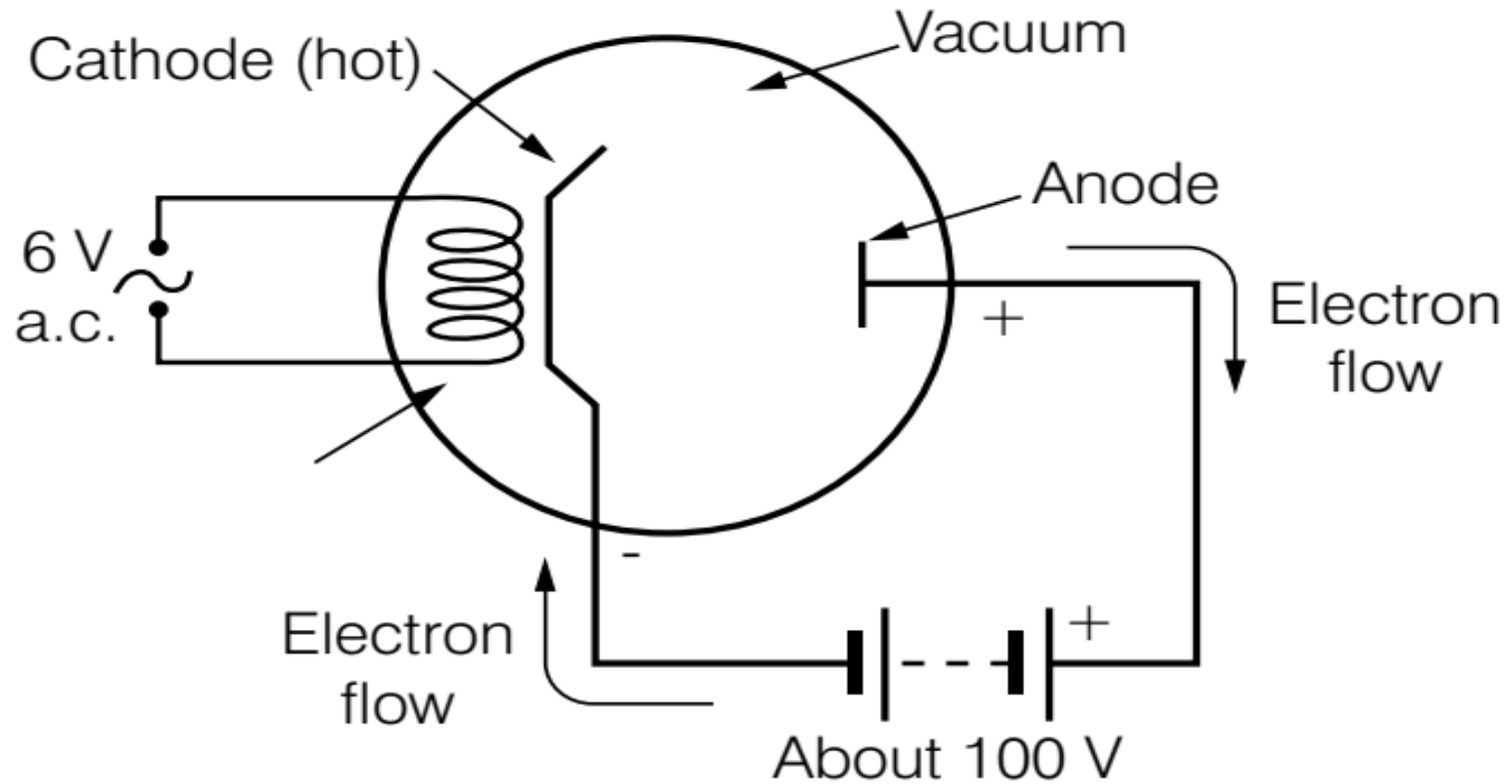

Thermionic diode.



2. Cathode rays

Definition: beams of high-speed electrons moving through a vacuum.

Production:

- ✓ electrons are emitted from a heated cathode
- ✓ accelerated through an anode with a high voltage ($\sim 5000V$).
- ✓ pass through a hole in the anode to form a focused beam.

Speed: electrons travel at about 1/10th the speed of light.

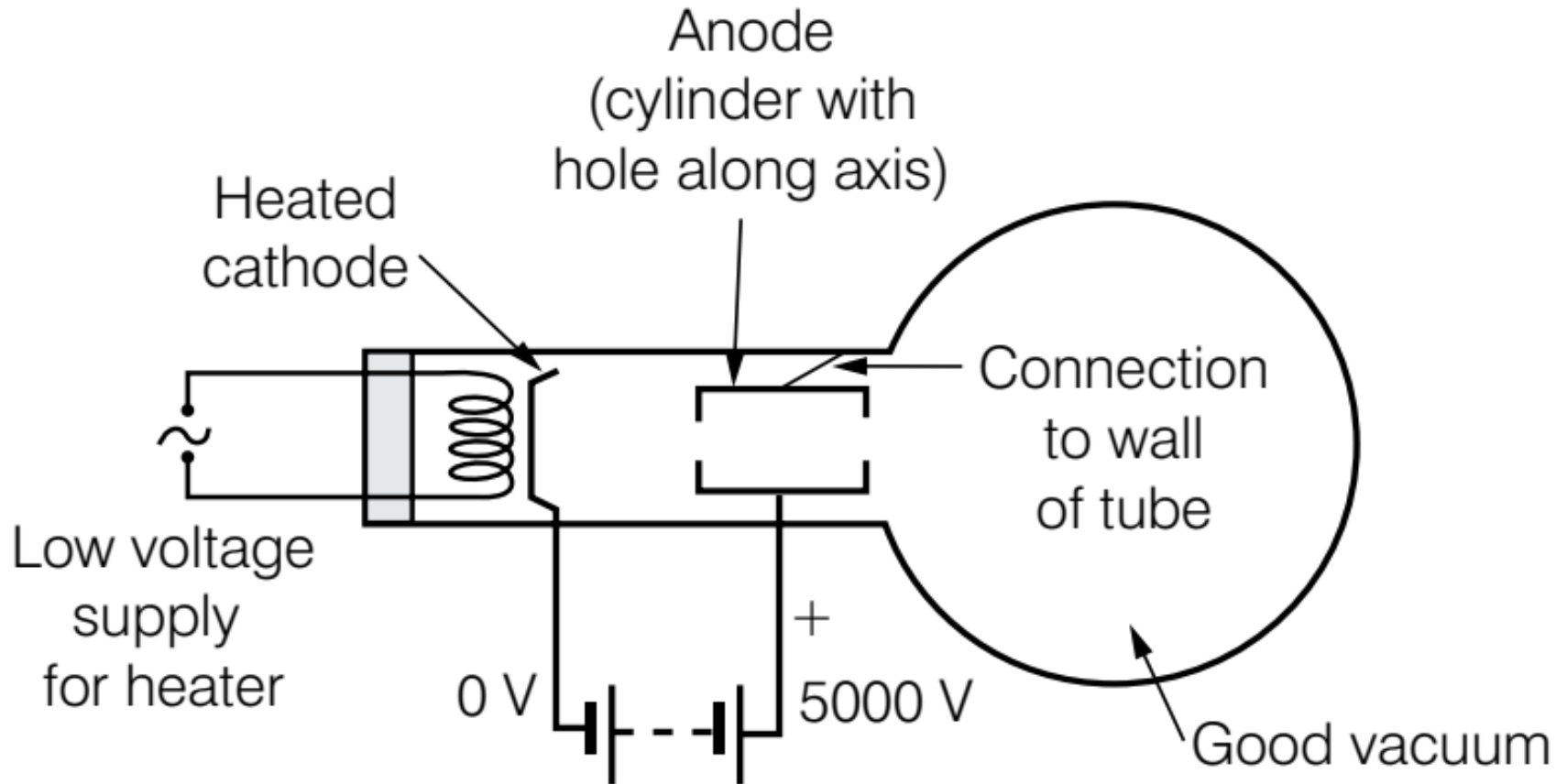

Electron gun.



3. X-ray tube

How it works:

- ✓ Electrons emitted from the cathode are accelerated by a high voltage (100kV) to hit the anode at high speed.
- ✓ The sudden deceleration produces X-ray

Heat management:

- ✓ most energy is released as heat.
- ✓ anode is made from copper for heat dissipation, with a tungsten tip to handle high temperatures.

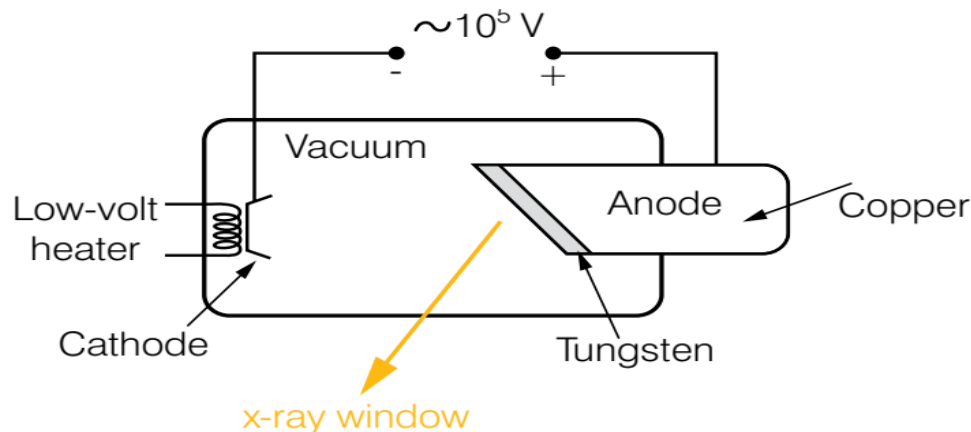



4. Cathode Ray Oscilloscope (CRO):

Function:

- ✓ displays electrical signals as a spot or line on a fluorescent screen.
- ✓ the electron beam is deflected by electric fields in the x and y directions.

Components

- **Electron gun:** produces the electron beam.
- **Deflection plates:**
 - y-plates:** move the beam vertically (for voltage changes).
 - x-plates:** move the beam horizontally (time base).
- **Screen:** fluorescent surface where the beam produces visible traces.

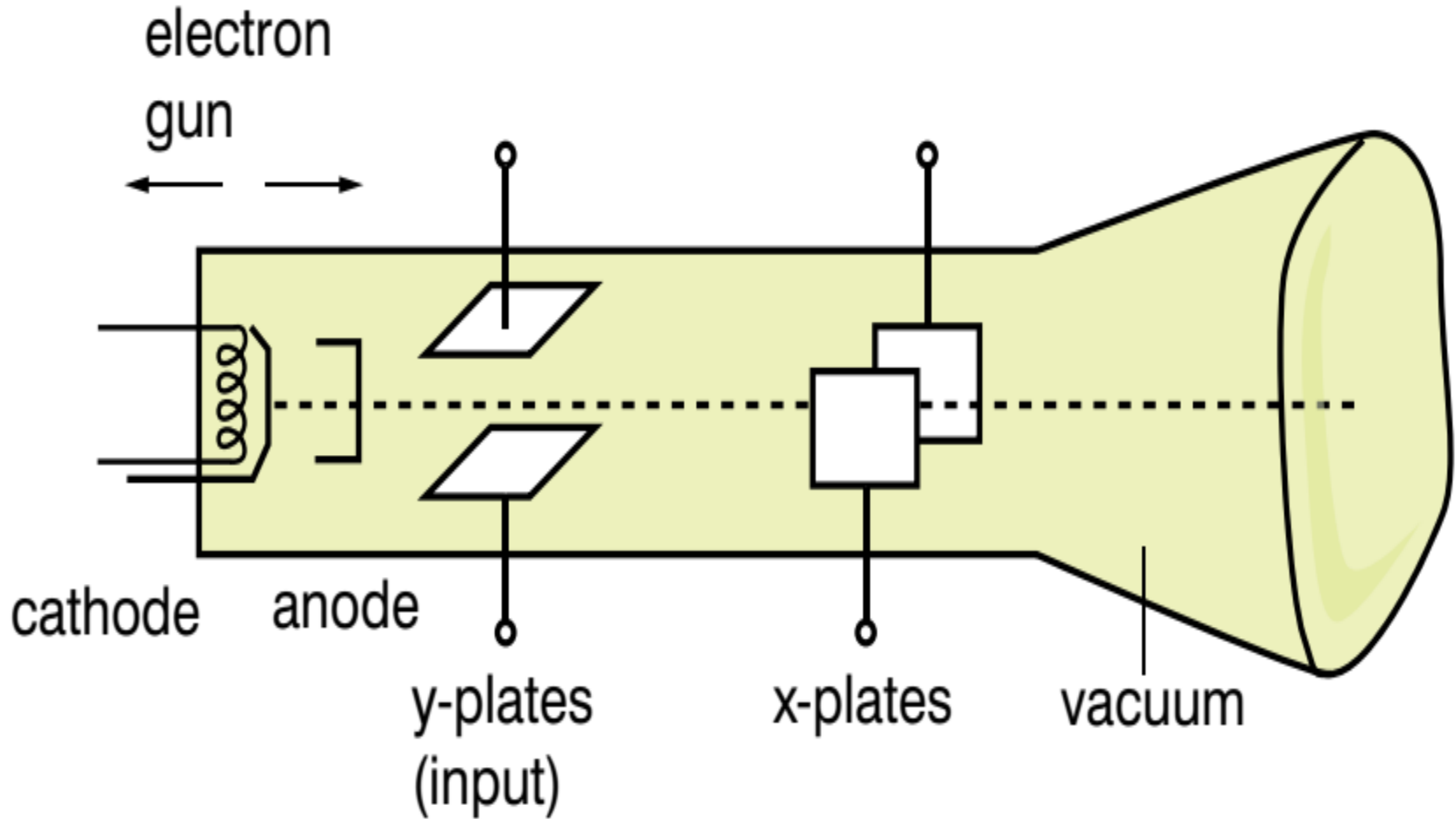



Applications of the CRO

1. DC voltage measurement:

- ✓ Displays a stationary spot or horizontal line.
- ✓ Can be calibrated to measure unknown voltage.

2. AC voltage measurement:

- ✓ Shows an alternating voltage as a sine wave.
- ✓ Time base is applied to produce continuous curve.

Sensitivity

- the size of the deflection caused by the voltage applied across the y plates of a CRO – can be adjusted using the gain control.

For example: if the sensitivity is set to 3 V/cm and the spot is deflected by 2 cm by an unknown p.d., the value of the p.d. must be $2 \times 3 = 6$ volts.

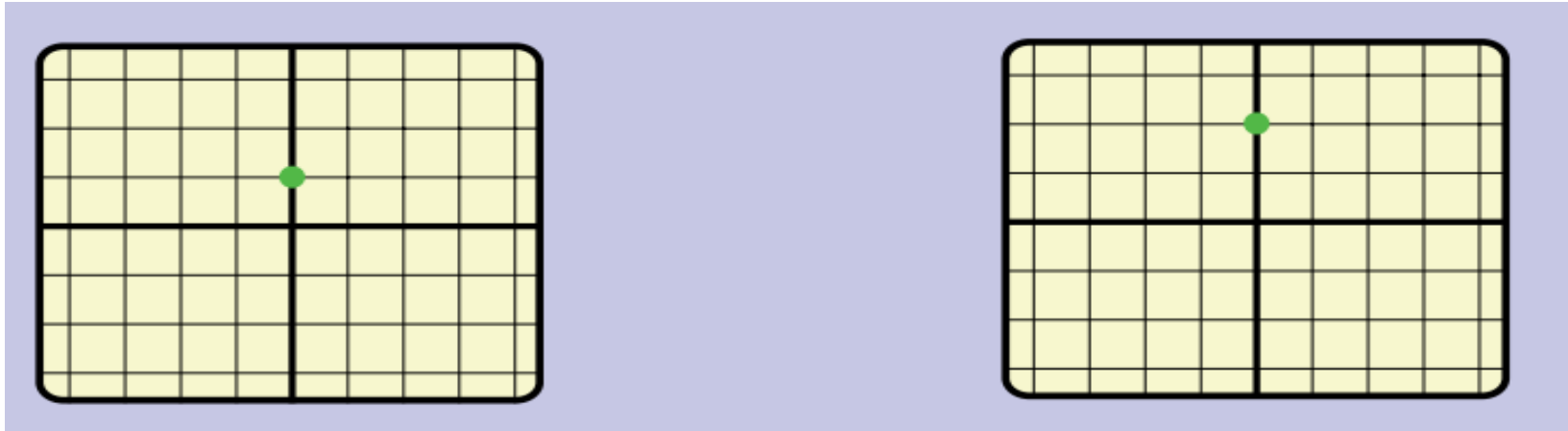

Time base

- The time base control can be calibrated (in milliseconds per cm) to show how long the spot takes to cross each centimetre of the screen. For example, if it is set to 1ms/cm the spot takes 1ms (1 millisecond) to move 1 cm to the right.

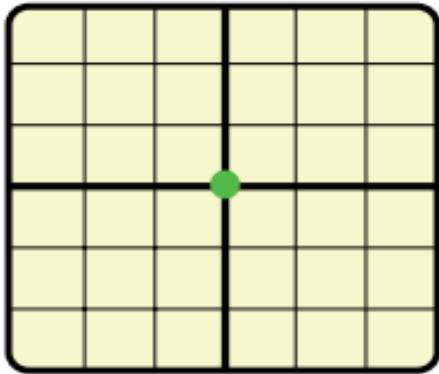

Time base off.

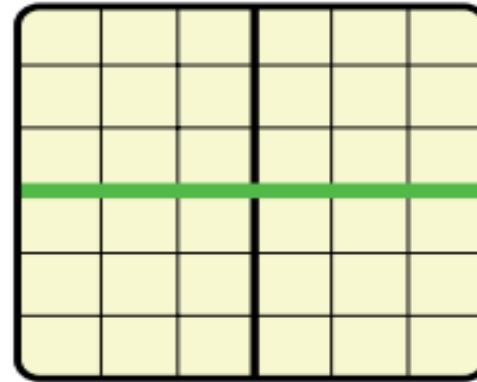

Time base on.

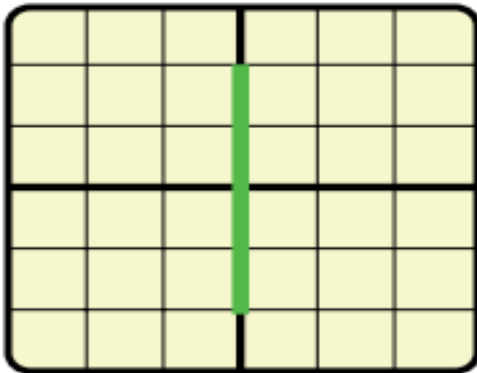

Time base off.

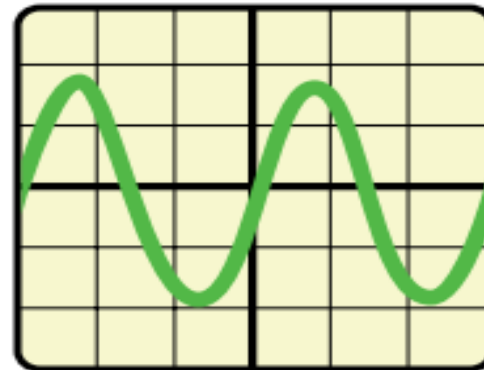

Time base on.



3. Frequency measurement:

✓ By comparing the waveform of unknown signal to a known one, the frequency can be calculated.

Example:

1. If a 50 Hz wave appears as one cycle and the unknown wave appears as two cycles, the unknown frequency is 100 Hz.

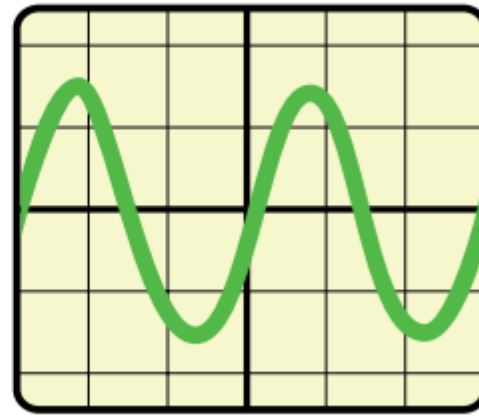
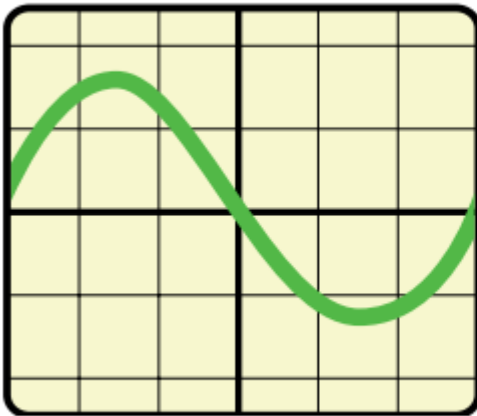



2. The trace on a CRO made by a 100 Hz signal fig(a). What is the frequency of the signal in Fig(b) (which was made without altering any of the CRO controls after measuring the 100 Hz signal)

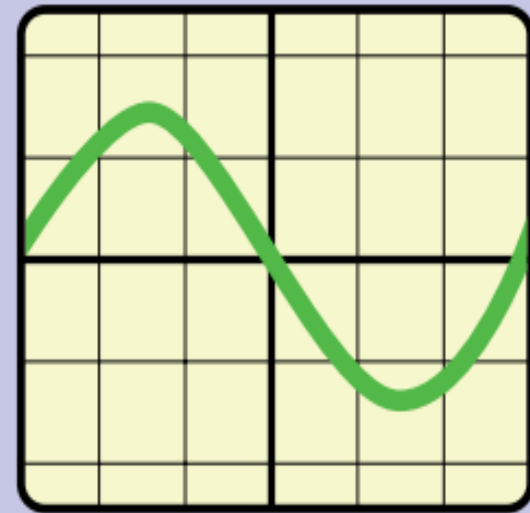
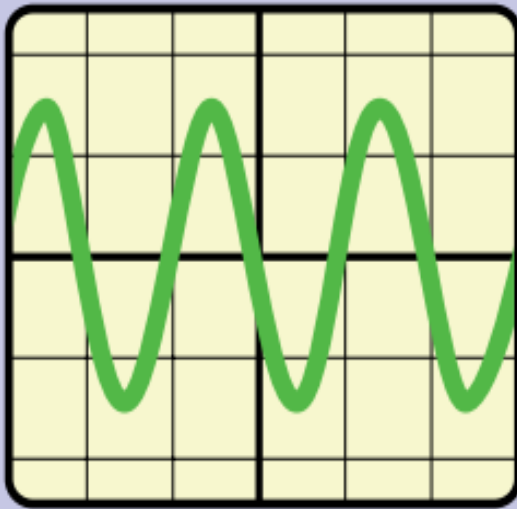



3. The sensitivity of a CRO is set as 5 V/cm , and the time base setting is 1 ms/cm . Find the peak voltage and frequency of the A.C. signal shown in Figure below.

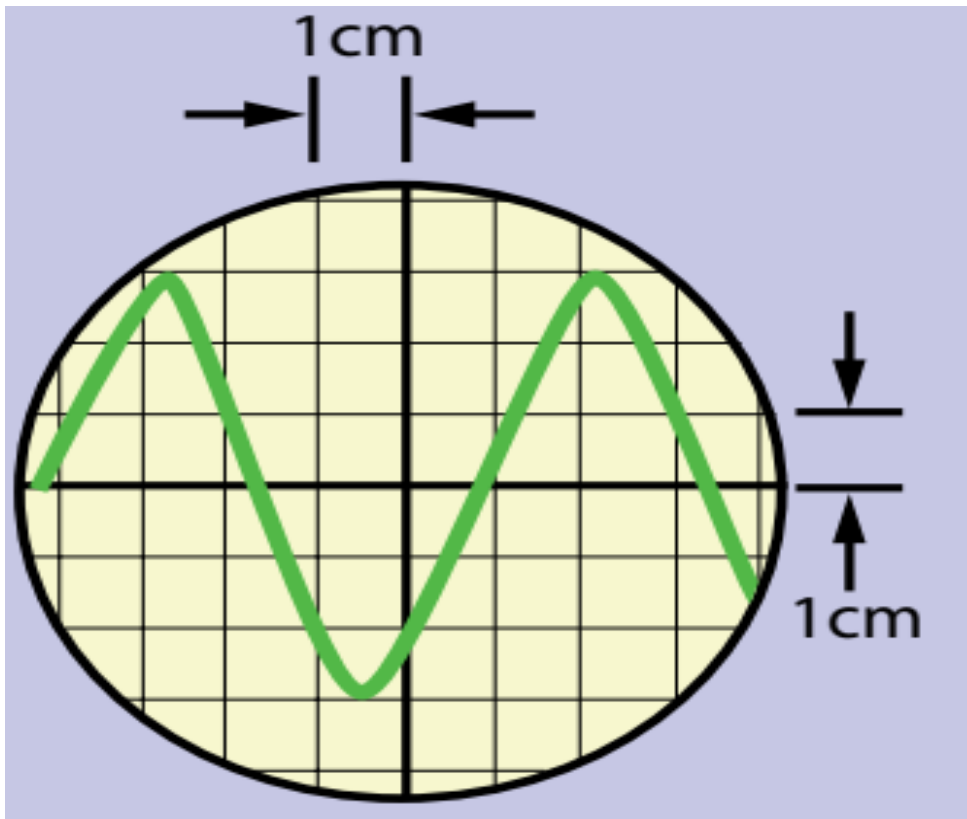



4. TV picture tube

- Similar to CRO:

- ✓ produces a moving spot of light on the screen
- ✓ currents through coils outside the tube generate magnetic fields to deflect the beam in an orderly path, forming the image.

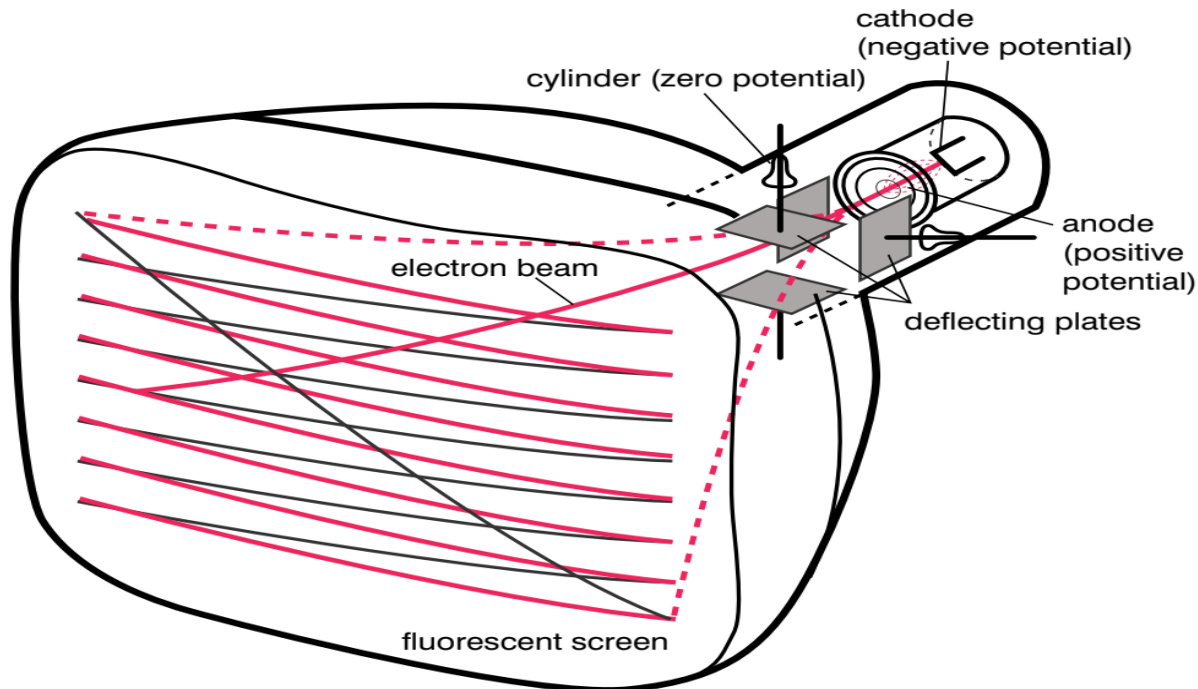



5.1 Conductors, Insulators, and Semiconductors

Conductors:

Materials that allow the easy flow of electric current due to the presence of free-moving electrons.

Key Characteristics:

Free Electrons: Conductors have electrons that are loosely bound to atoms and can move freely within the material.

Common Examples: Metals such as **copper**, **aluminum**, and **silver**.

Applications: Conductors are used in **electrical wiring**, **power transmission lines**, and **electrical circuits** due to their excellent ability to carry current with minimal resistance.



Insulators:

- ✓ Materials that resist the flow of electric current because their electrons are tightly bound to atoms and cannot move freely.

Key Characteristics:

No Free Electrons: Insulators lack free electrons, preventing electrical conductivity.

Common Examples: Plastic, wood, glass, and rubber.

Applications: Insulators are used to coat electrical wires and components, ensuring that electricity does not leak into unintended areas, protecting users and devices from electrical hazards.



Semiconductors:

Definition: Materials that have electrical conductivity between that of conductors and insulators.

✚ Their conductivity can be modified by external factors such as **temperature**, **light**, or **doping**.

Key Characteristics:

Temperature-Dependent Conductivity: At absolute zero, semiconductors behave like insulators. At higher temperatures, electrons gain enough energy to break free from their atomic bonds, allowing current to flow.

Common Examples: **Silicon** (Si), **Germanium** (Ge), and compound materials like Gallium Arsenide (GaAs).



Lattice Structure of Semiconductors:

Covalent Bonding: Semiconductors like silicon consist of atoms bonded in a crystal lattice, where each atom forms covalent bonds with four neighboring atoms, sharing electrons to create stable structures.

Electron-Hole Pair: When electrons gain energy and move away from their atoms, they leave behind "holes," which act as positive charge carriers.

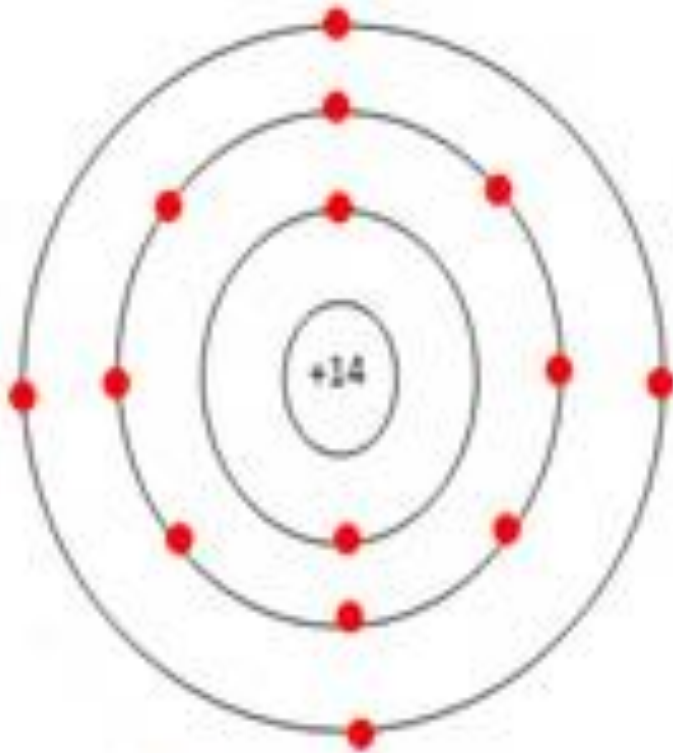

(a)

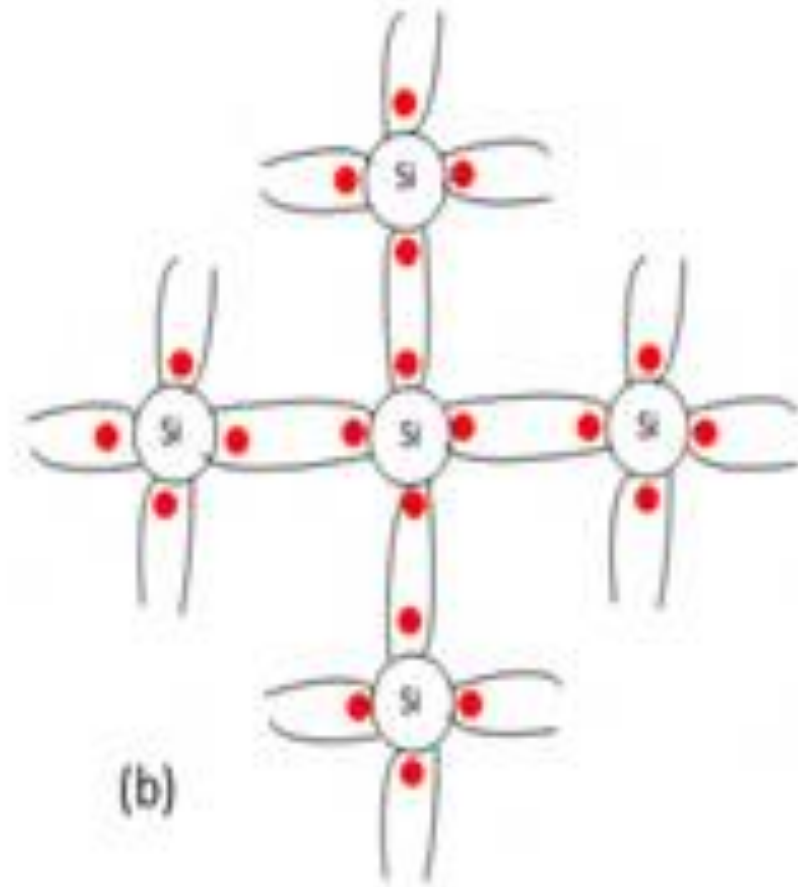

(b)

Figure : a) Electron structure of silicon atom b) covalent bond in silicon.

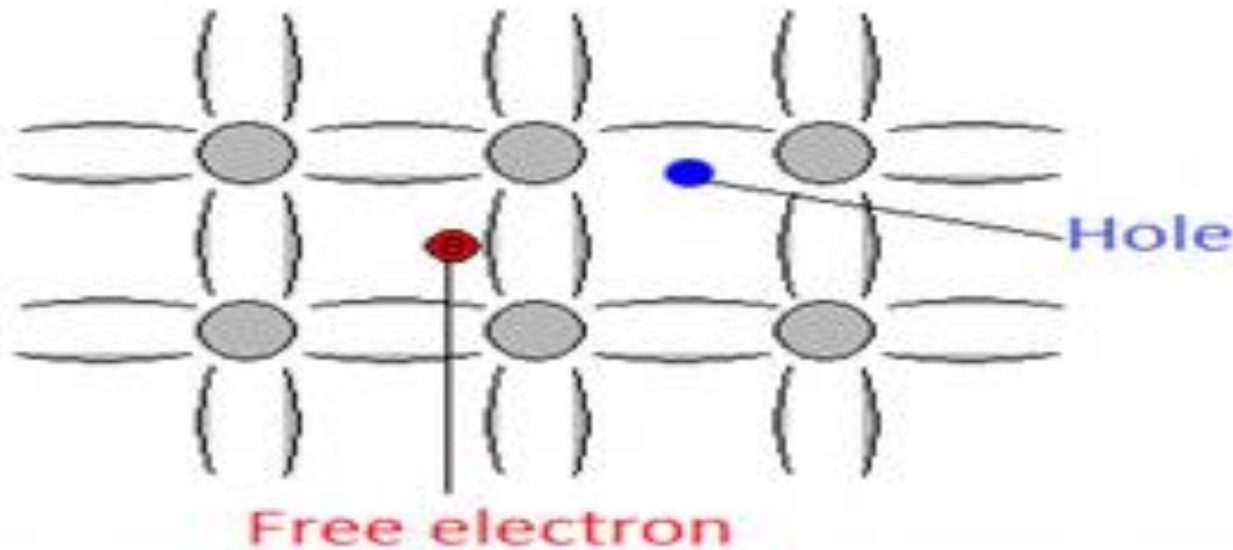

Figure : Free electron and hole in semiconductor.

Types of Semiconductors

1. Intrinsic Semiconductors:

Definition: Pure semiconductor materials without any impurities



Key Characteristics:

- ✓ Their conductivity is solely determined by the temperature and the intrinsic properties of the material.
- ✓ Silicon and germanium are common intrinsic semiconductors.

Applications: Used in research and basic semiconductor studies as they provide a controlled environment for understanding the behavior of semiconductors.

2. Extrinsic Semiconductors:

Definition: Semiconductors that have been intentionally doped with impurities to enhance their electrical properties.



Doping: The process of adding small amounts of impurities to intrinsic semiconductors to change their conductivity.

- ✓ The dopants either introduce **more electrons** or create **more holes** in the material.

Types of Extrinsic Semiconductors:

N-Type Semiconductors:

Doped with Group V Elements: Elements like **phosphorus** (P) or **arsenic** (As), which have five valence electrons.

Key Characteristics: The extra electron from the dopant is free to move, making electrons the majority charge carriers.

Conductivity: Dominated by the flow of electrons (negative charge), which gives it the name "N-type" (Negative-type).



Example: Silicon doped with phosphorus.

P-Type Semiconductors:

Doped with Group III Elements: Elements like boron (B) or aluminum (Al), which have only three valence electrons.

Key Characteristics: The lack of one electron creates a "hole" in the crystal lattice, which acts as a positive charge carrier.

Conductivity: Dominated by the movement of holes (positive charge), which gives it the name "P-type" (Positive-type).

Example: Silicon doped with boron.



Charge Carriers in Semiconductors

Electrons: Negatively charged particles that move through the material when a voltage is applied.

- ✓ They are the majority carriers in N-type semiconductors.

Holes: Positively charged carriers created when an electron is absent from its normal position in a crystal lattice.

- ✓ Holes are the majority carriers in P-type semiconductors.

Current Flow: In semiconductors, current is carried by both electrons and holes.

- ✓ *In N-type materials, the majority of current is due to electron flow, while in P-type materials, holes are responsible for most of the current.*

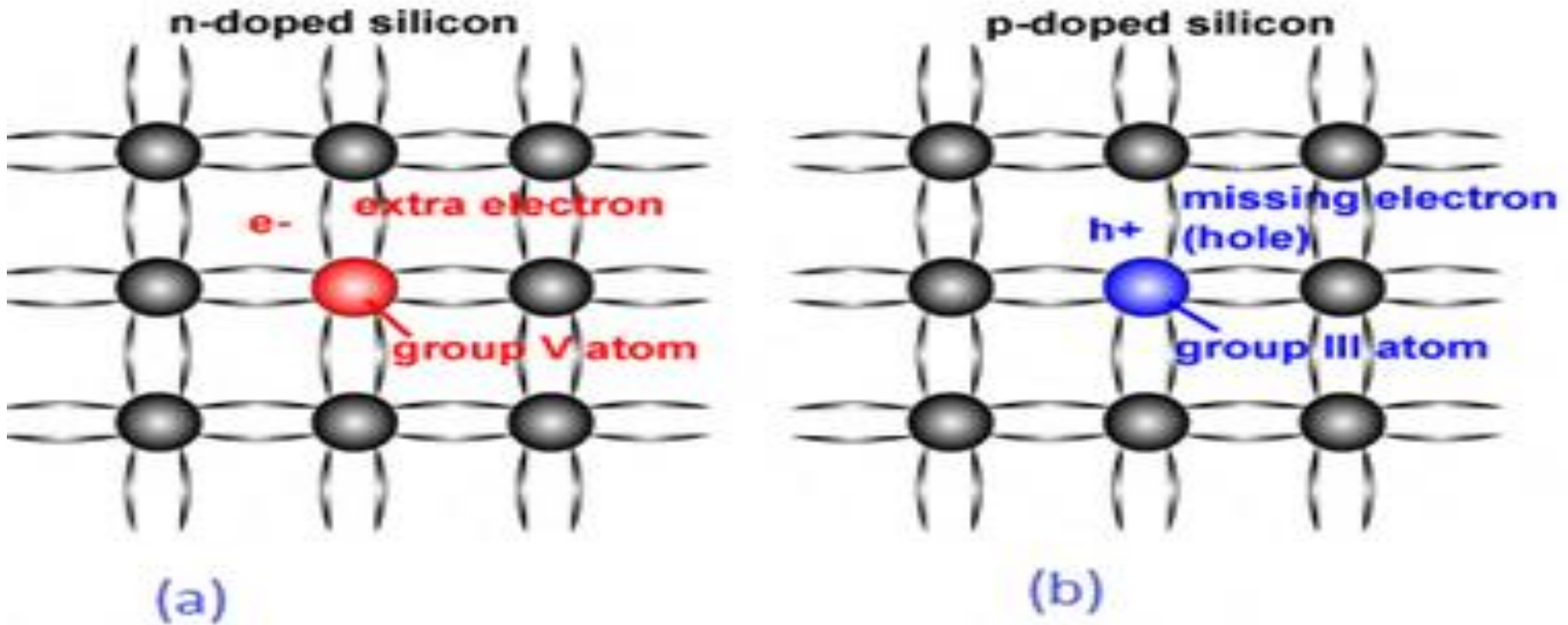

Figure : (a) Si crystal doped with Arsenic element. For each Arsenic atom present in the Si crystal, there is one extra electron.
 (b) Si crystal doped with Boron. For each Boron atom present in the Si crystal, there is one less electron.



Practical Applications of Semiconductors

Diodes: Semiconductor devices that allow current to flow in only one direction, using a junction between P-type and N-type materials.

Transistors: Used in amplification and switching applications, transistors utilize the properties of semiconductors to control the flow of current in circuits.

Integrated Circuits (ICs): ICs are made by combining many semiconductor devices into a single chip, enabling the creation of complex electronic systems such as **computers**, **smartphones**, and **microcontrollers**.



5.2 Diodes and Their Functions

Diode: Two-terminal electronic component.

- **Function:** Conducts current in one direction, blocks in reverse.
- **Terminals:** Anode (-), Cathode (+).
- **Materials:** Silicon, Germanium, Gallium Arsenide.

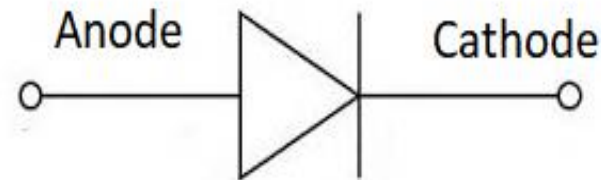

Figure : a) The p-n junction diode b) p-n junction symbol.



P-N Junction Diode

- Formation: Joining p-type and n-type semiconductors.
- Symbol: Arrow points in the direction of conventional current flow.

Depletion Region:

- Electrons and holes combine at the junction.
- Creates a region with few mobile carriers.
- Barrier Potential:
 - Silicon: 0.7V
 - Germanium: 0.3V

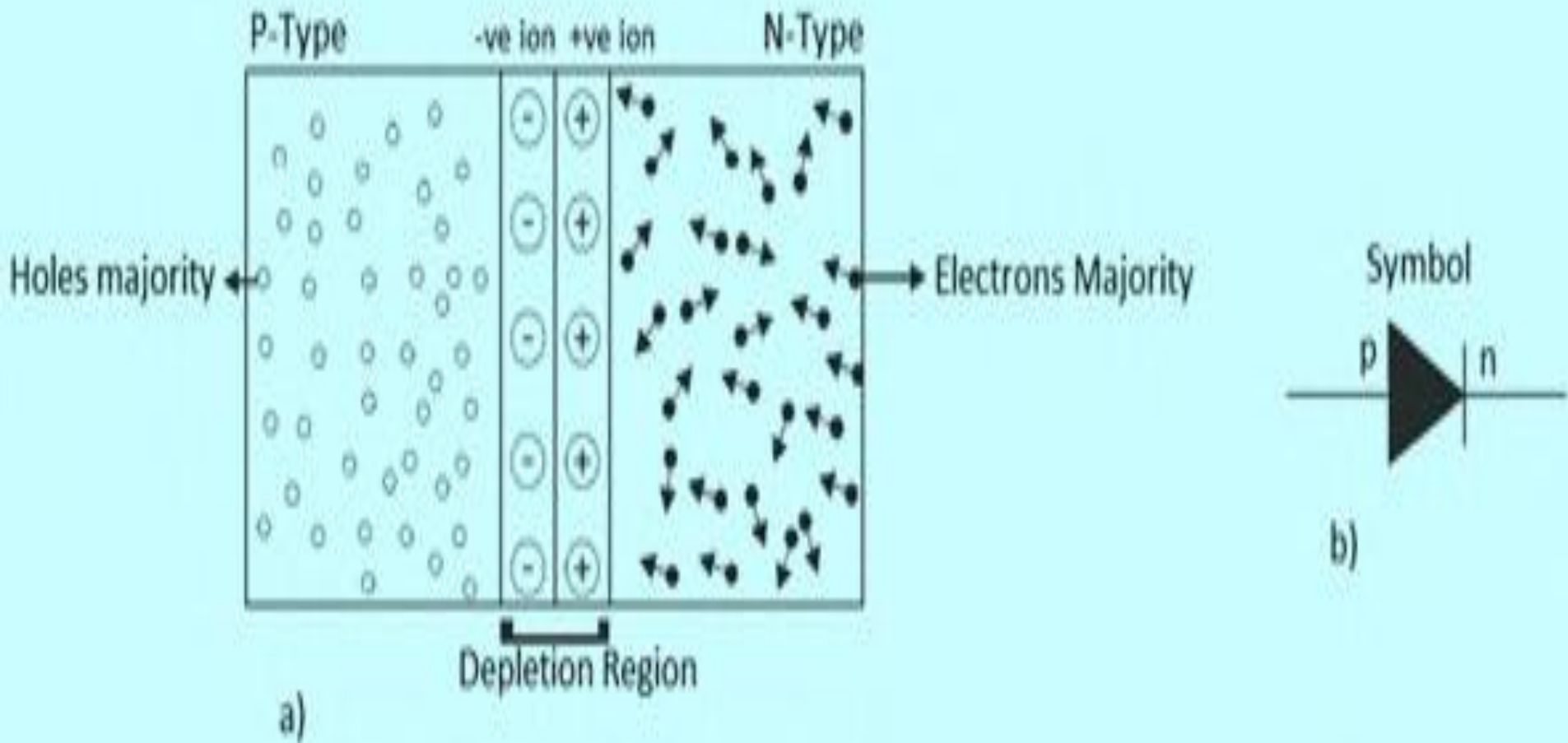

Figure : The p-n junction diode formed between p-type and n-type semiconductors.



Biasing of P-N Junction Diode

Forward Bias:

- ✓ Positive terminal to P-type, negative terminal to N-type.
- ✓ Decreases depletion region width.
- ✓ Diode conducts current.

Reverse Bias:

- ✓ Positive terminal to N-type, negative terminal to P-type.
- ✓ Increases depletion region width.
- ✓ No current flows, except leakage current.

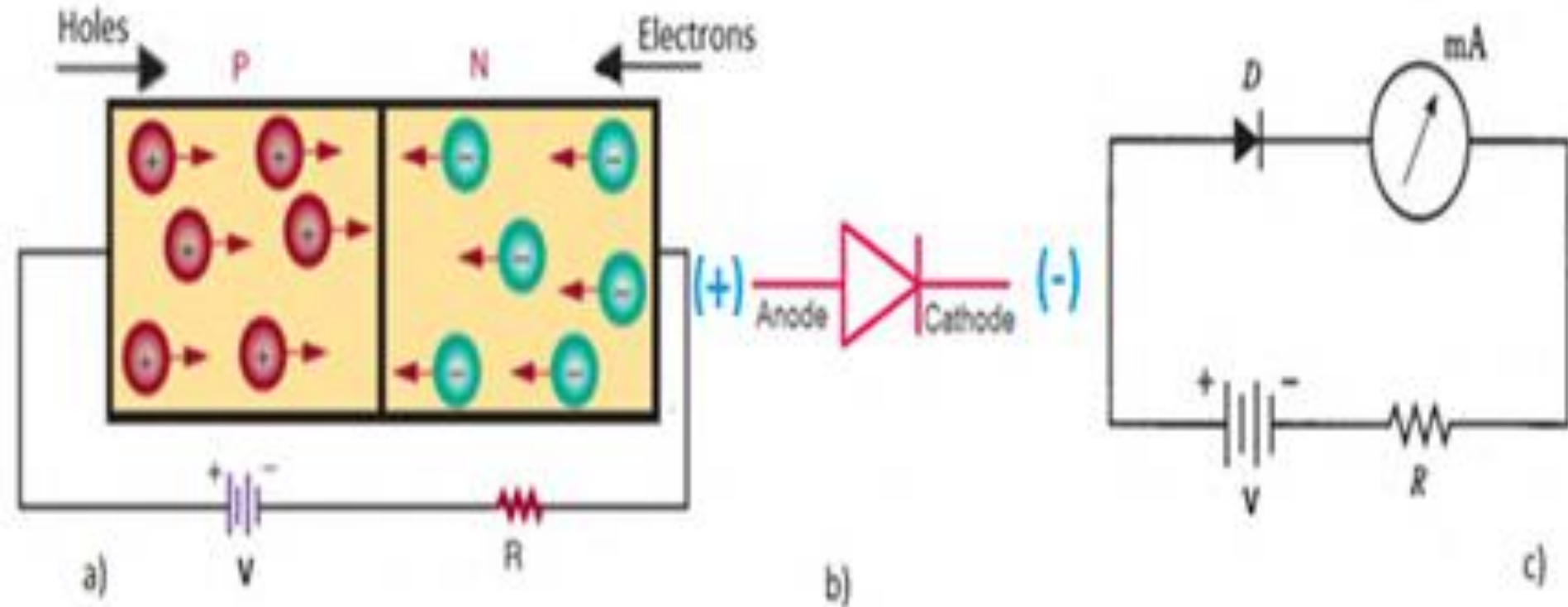

Figure : (a) Forward biased p-n junction (b) symbol representing forward biased p-n junction (c) Forward biased circuit diagram.

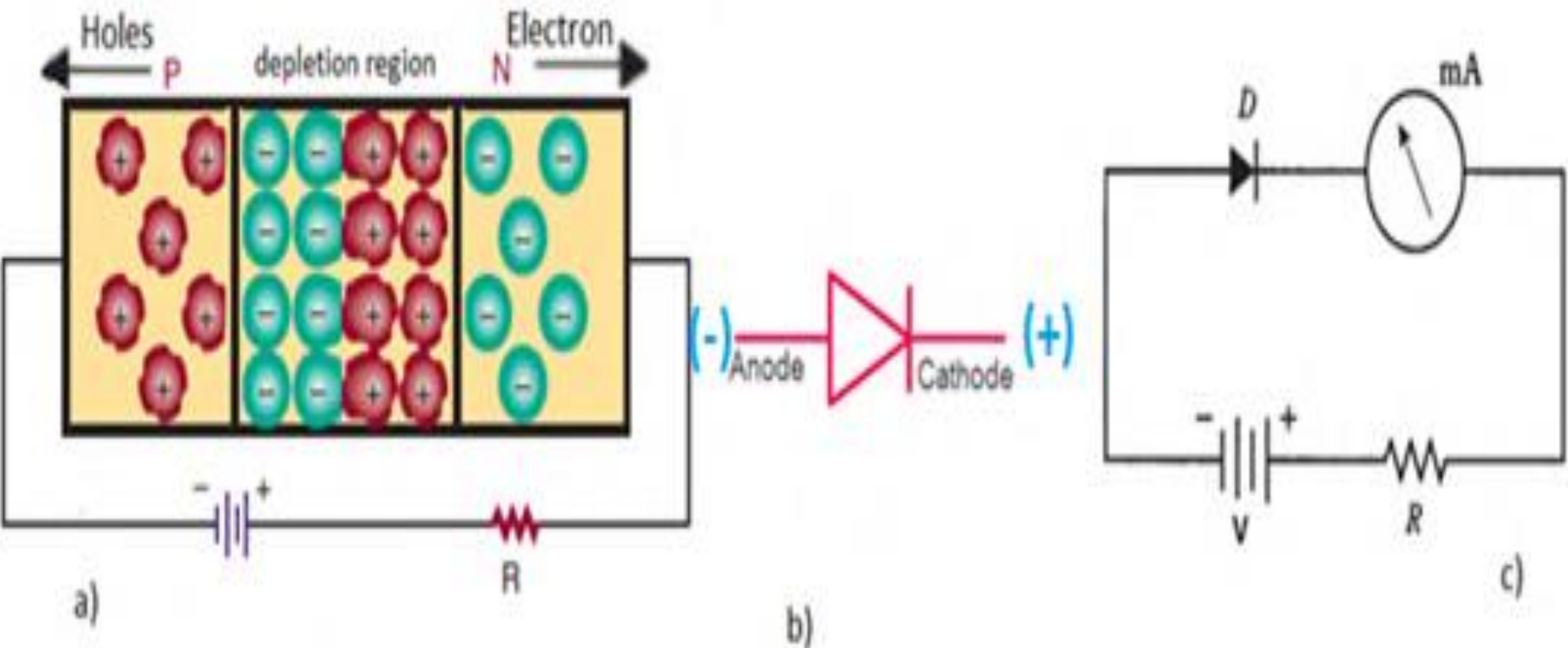

Figure : (a) Reverse biased p-n junction (b) symbol representing reverse biased p-n junction (c) reverse biased circuit.



Current-Voltage (I-V) Characteristics

Forward Bias:

- Non-linear current rise initially.
- Rapid increase after barrier voltage is exceeded

Reverse Bias:

- Small leakage current.
- Sharp current increase at breakdown voltage.

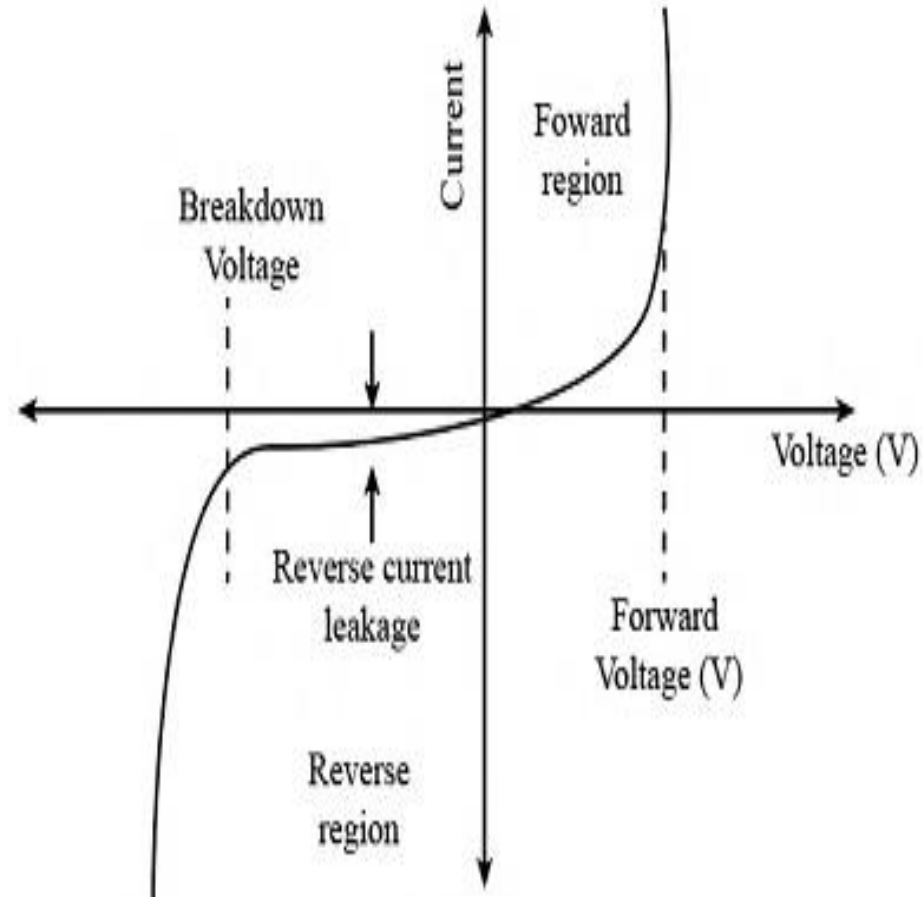

Figure: I-V Characteristics of p-n junction diode.



Applications of Diodes

- ✓ Rectifiers: AC to DC conversion.
- ✓ LEDs: Light-emitting diodes.
- ✓ Solar Cells: Convert light to electricity.
- ✓ Voltage Clamping: Protect circuits from spikes.

Discussion Questions:

1. What is the difference between forward and reverse biasing?
2. Give examples of the application of diodes in daily life.



Rectification and Diodes:

Key Concepts: Half-Wave & Full-Wave Rectifiers, Diode applications

Rectification Overview

- **Rectification:** Process of converting AC voltage to DC.
- **Rectifier:** Electric circuit used for rectification.

Types:

- Half-Wave Rectifier
- Full-Wave Rectifier

Half-Wave Rectifier

Definition: Allows only one half-cycle of AC to pass, blocking the other.



Working Principle:

- ✓ During the positive half-cycle, the diode is forward-biased and current flows.
 - ✓ In the negative half-cycle, the diode is reverse-biased, blocking current.
- ⇒ Output: Pulsating DC signal.

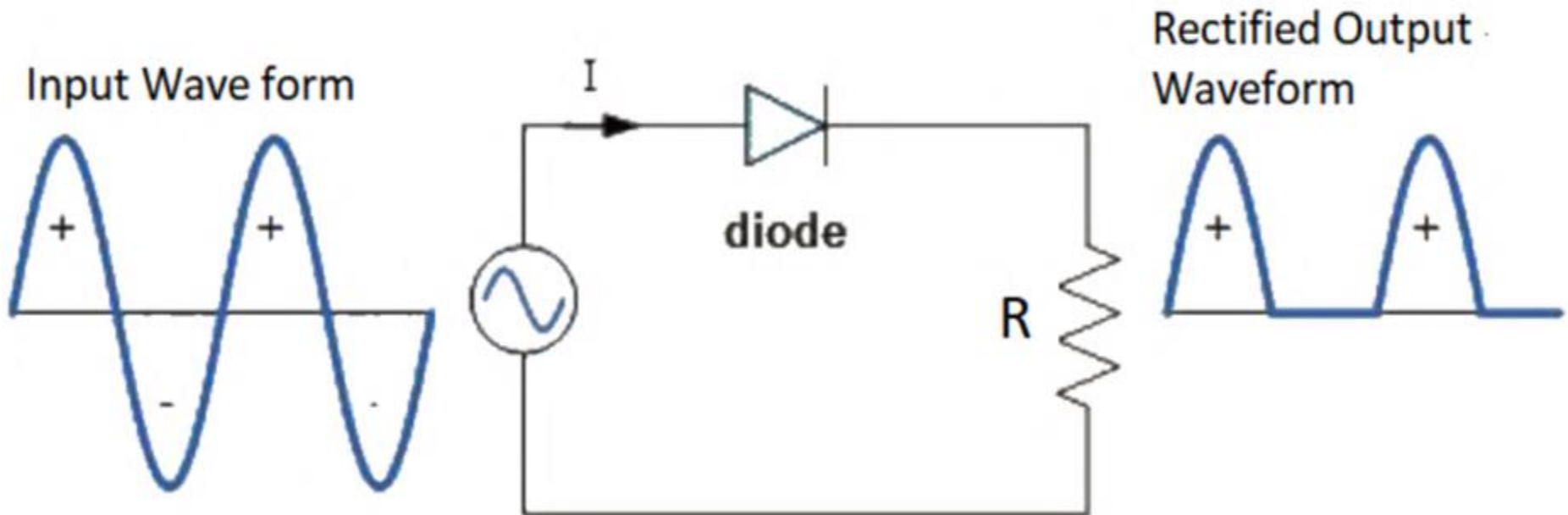



Full-Wave Rectifier

Definition: Converts both half-cycles of AC into DC using multiple diodes.

Working Principle:

- ✓ During the positive half-cycle: Diodes D_1 and D_2 conduct.
- ✓ During the negative half-cycle: Diodes D_3 and D_4 conduct.
- ✓ Current flows in the same direction in both cycles.

Advantage: More efficient than half-wave rectifier.

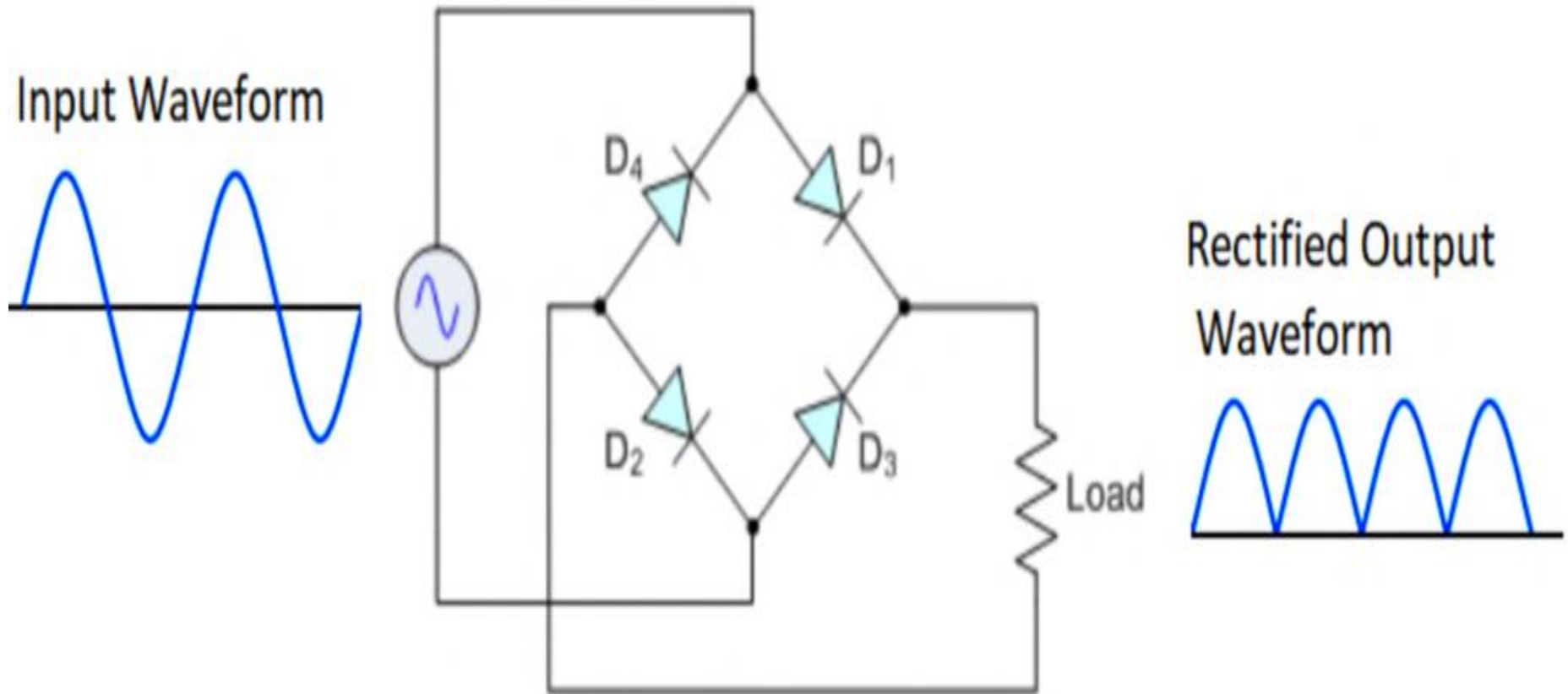

Figure : Basic full-wave rectifier circuit.



Capacitor in Rectification

Purpose: Smoothens the output voltage of the rectifier.

Operation:

- ✓ Capacitor charges during the peak voltage and discharges when voltage drops, providing a more stable DC output.

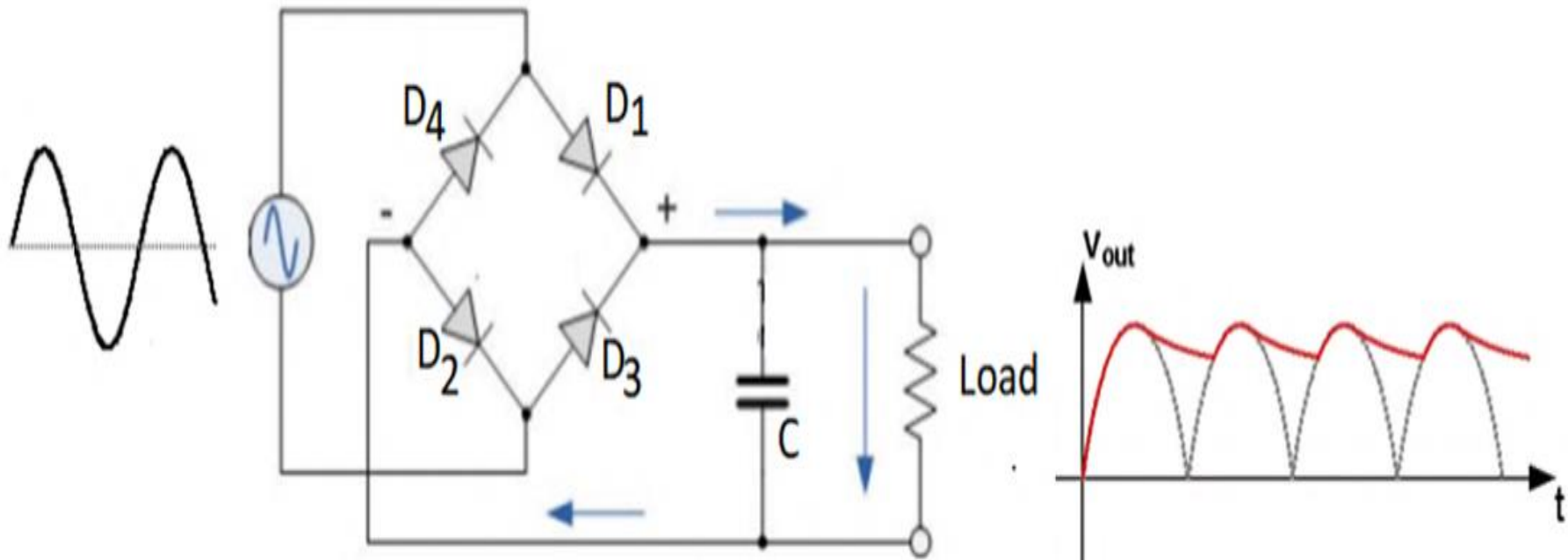

Figure: Smoothing output voltage using a capacitor in full wave rectifier



Diode Applications

- Rectification: Converts AC to DC (discussed).
- Light Emitting Diode (LED):
 - Emits light when forward-biased.
 - Used in lighting and displays.



a)

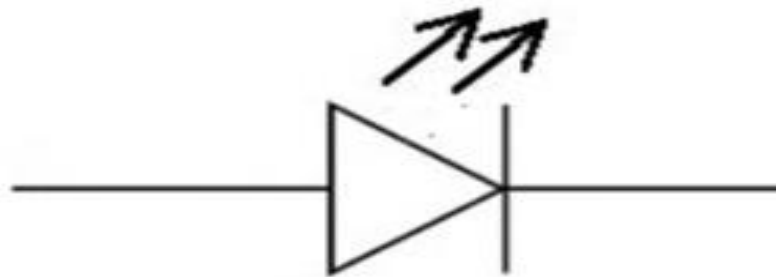

b)

Figure: a) LED

b) LED Symbol



- **Photodiode:**
 - Converts light into electrical current.
 - Used in sensors and communication systems.

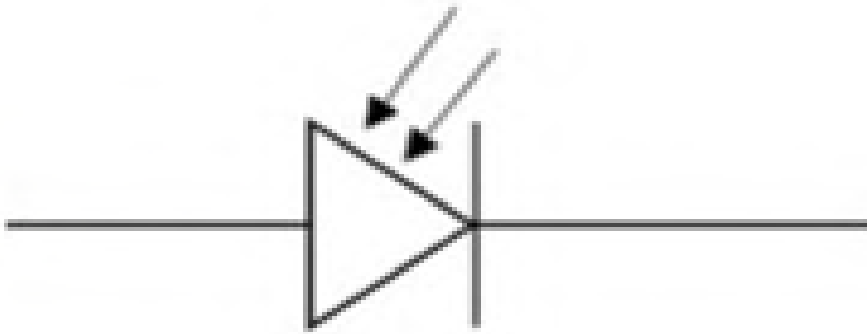

Figure : Photodiode Symbol.

- **Over-voltage Protection:** Diodes protect devices from excess voltage.
- **Logic Gates:** Diodes can form basic AND/OR gates in circuits.



Conclusion

Key Points:

- ✓ Rectifiers are crucial for converting AC to DC.
- ✓ Diodes have various practical applications in electronics.

Transistors and Their Applications

Key Topics: Types of Transistors, Working Principles, and applications

Transistor Overview

Transistor: Three-terminal device used to control electron flow.

Types:

- Bipolar Junction Transistors (BJT)
- Field Effect Transistors (FET)

Applications: Amplification and switching.



Bipolar Junction Transistors (BJT)

Two Types:

- NPN Transistor: P-type sandwiched between two N-type materials.
- PNP Transistor: N-type sandwiched between two P-type materials.

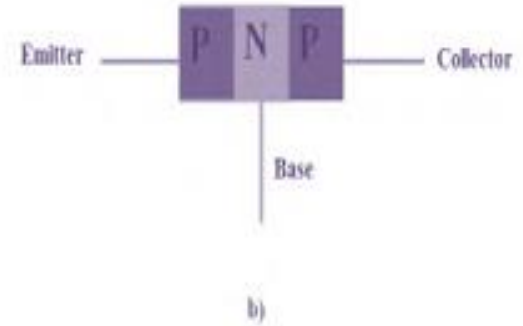
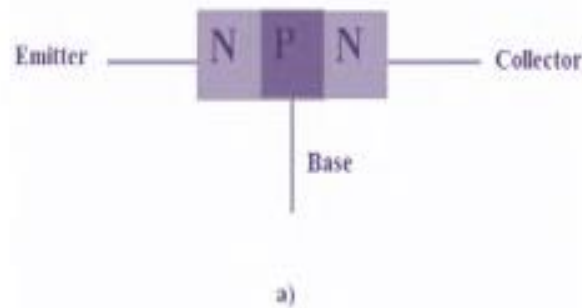

Terminals:

- Emitter (E): Supplies charge carriers.
- Base (B): Thin and lightly doped, controls flow.
- Collector (C): Collects charge carriers.



Transistor Operation (NPN Example)

NPN Transistor:

- Emitter-Base junction: Forward biased.
- Base-Collector junction: Reverse biased.
- Current Flow: Electrons move from emitter to collector.

$$\text{Equation: } I_E = I_C + I_B$$

PNP Transistor Operation

PNP Transistor:

- Emitter-Base junction: Forward biased with opposite polarity.
- Holes are the majority current carriers.
- Similar operation to NPN but with reversed polarities.



Figure: Schematic symbol for (a) NPN transistor & (b) PNP transistor.

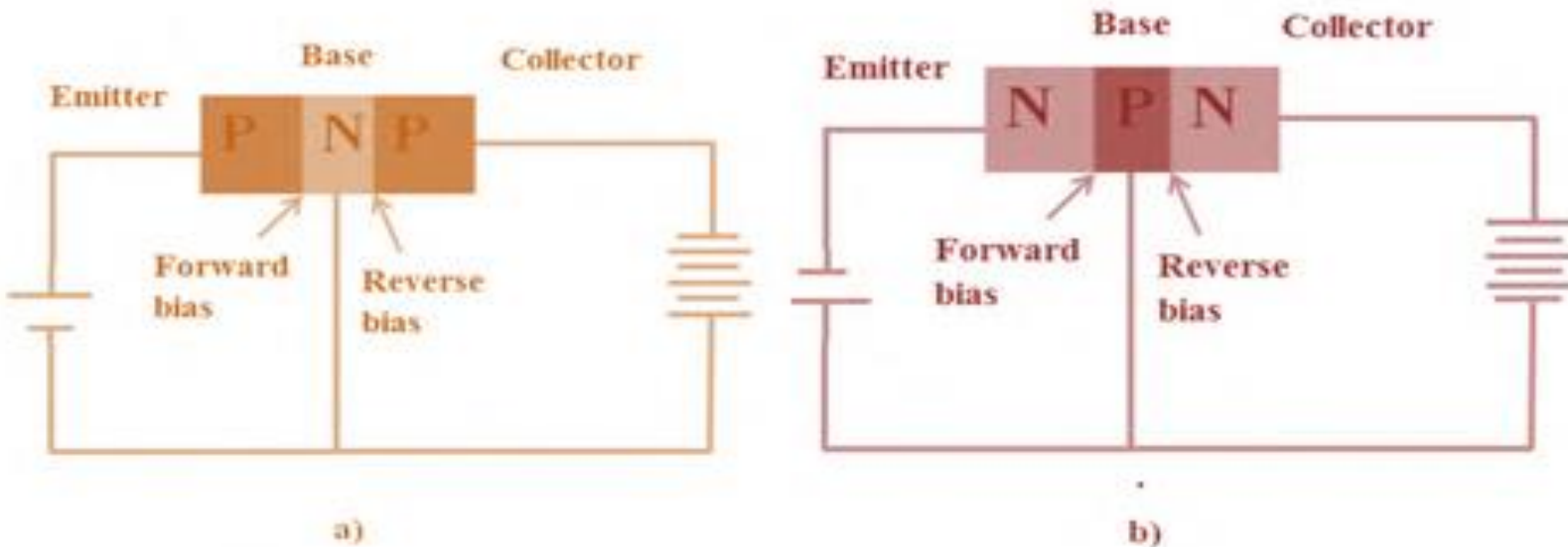

Figure: a) PNP transistor b) NPN transistor

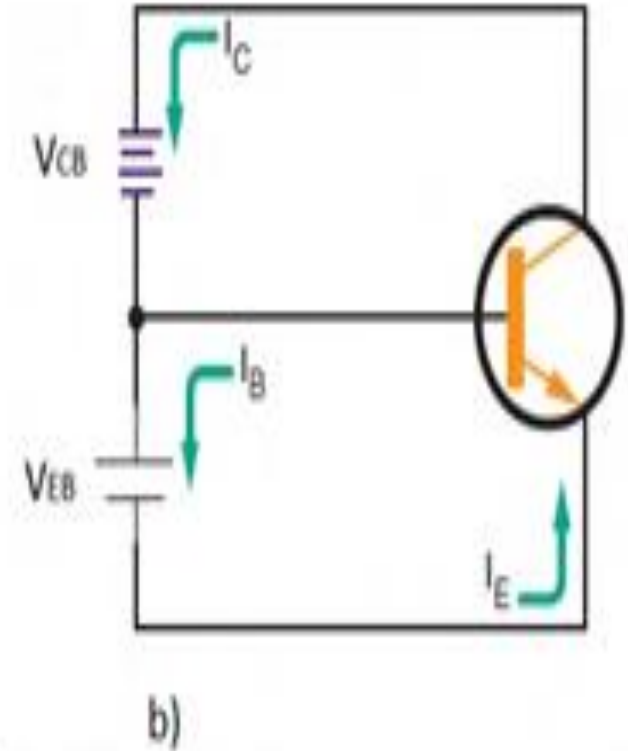
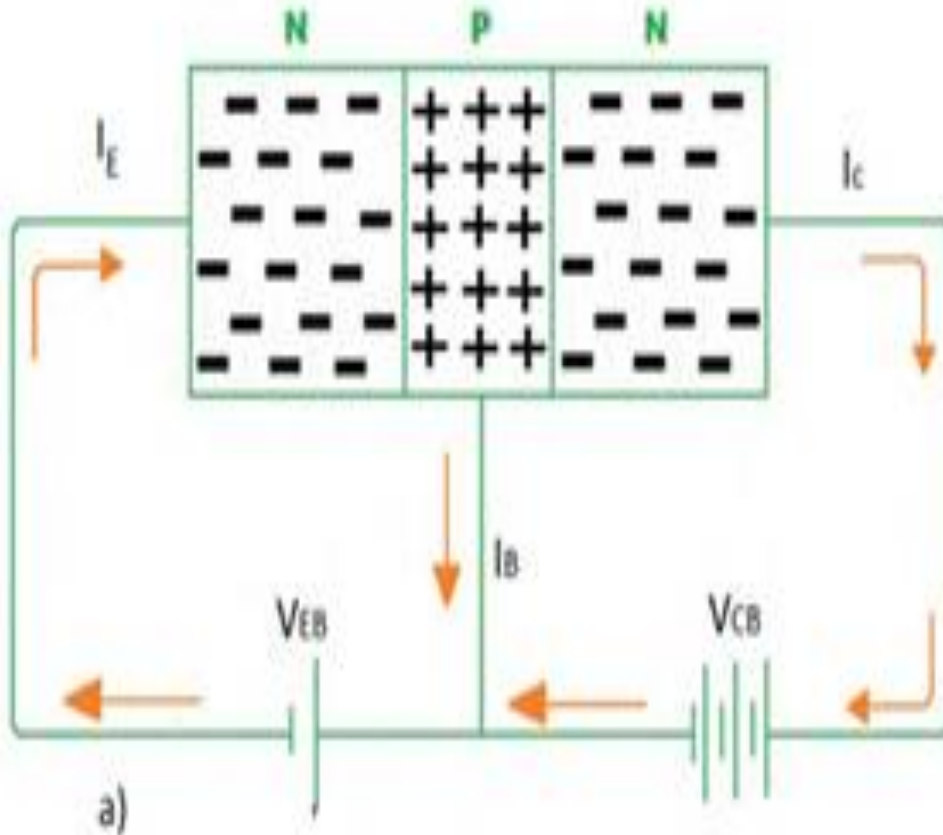
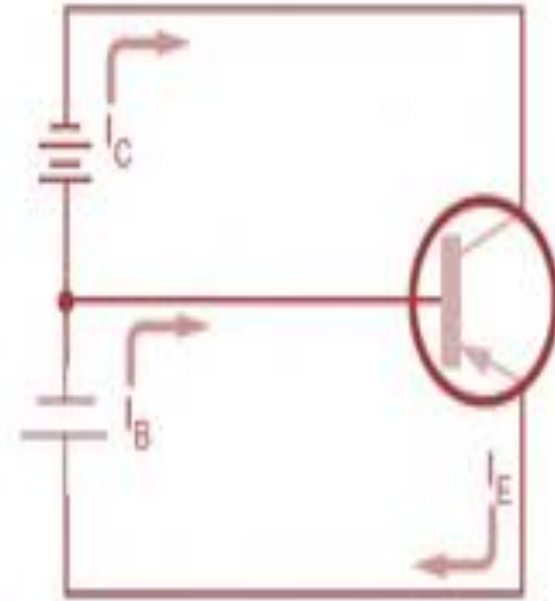

Figure: Electron current flow in NPN transistor a) Block diagram NPN transistor
b) Schematic diagram of NPN transistor



a)



b)

Figure: Electron current flow in PNP transistor. a) Block diagram of a biased PNP transistor b) Schematic diagram of a biased PNP transistor.



Transistor Configurations

Common Configurations:

- **Common Base:**

Orientation: input at emitter, output at collector, base common.

Function: High voltage gain and low current gain.
used in high frequency applications.

- **Common Collector:**

Orientation: input at base, output at emitter, collector common.

Function: No voltage gain and high current gain.
used for impedance matching & driving loads.



Common Emitter:

Orientation: input at base, output at collector, emitter common.

Function: High voltage and current gain.

Used for signal amplification.

✓ *the current gain is usually denoted by β .*

$$\beta = \frac{I_C}{I_B}, \quad I_E = I_C + I_B$$

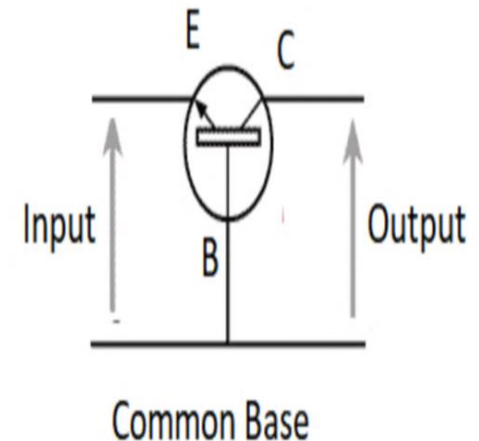
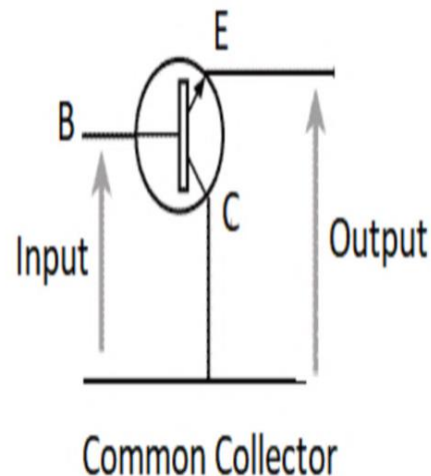
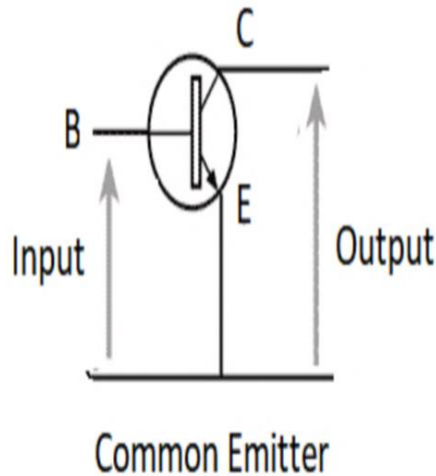



Transistor Gain and Example

A transistor has a β of 250 and a base current of $20\mu\text{A}$. What is the collector current?



Output Characteristics of common emitter

- ❖ Shows how I_C changes as the collector-emitter voltage (V_{CE}) increases while keeping the I_B constant.

Key points

- ✓ I_B is kept constant while v_{CE} is varied.
- ✓ The graph typically includes multiple curves, each representing different I_B .
- ✓ Even though I_B is small (in μA), the corresponding I_C is significantly larger (in mA) → demonstrates the transistor amplification property.

Regions

1. cut-off region

- ✓ $I_B = 0$, so $I_C = 0$ regardless of V_{CE}
- ✓ The transistor is off.



2. Active region

- For a given I_B , increasing V_{CE} initially increases I_C , but eventually stabilizes.
- This region shows that small change in I_B (in μA) results in large change in I_C (in mA) \longrightarrow **high current gain.**
 - ✓ *For example: a change of $10 \mu A$ in I_B might result in a $2 mA$ change in I_C reflecting a current gain of 200.*

3. Saturation region

- I_C reaches its maximum value and stops increasing, even if V_{CE} is further increased.
- The transistor is fully on.

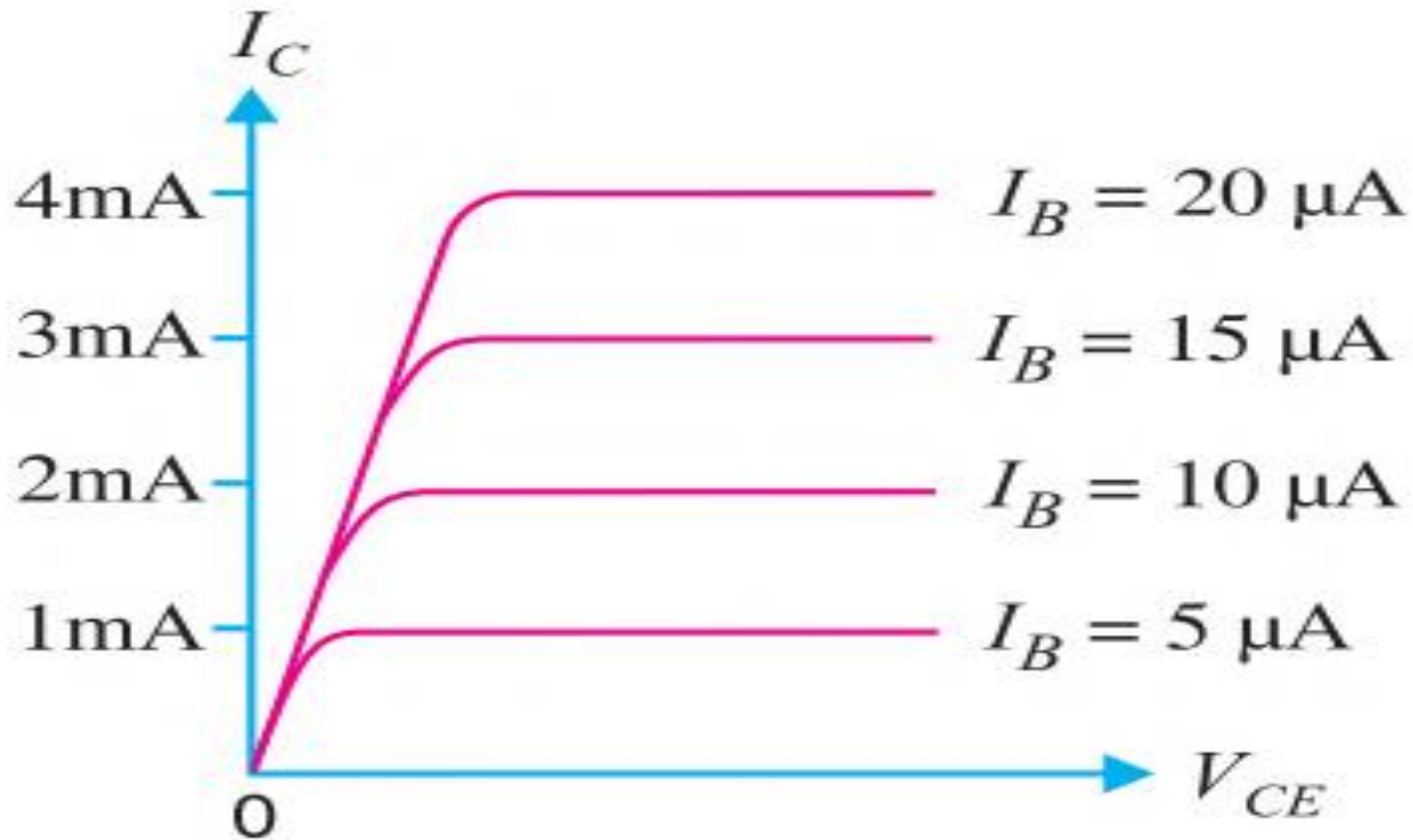

Figure : Output characteristics of common emitter transistor.



Practical Applications of Transistors

- **Amplifiers:** Common emitter configuration.
- **Switching:** Controls electronic devices.
- **Integrated Circuits:** Basis for IC design in modern electronics.

Conclusion

Summary:

- ✓ BJT's control current flow using three terminals.
- ✓ They are essential in amplification and switching applications.



5.5 Integrated Circuits (IC)

Definition: An integrated circuit (IC), also known as a microchip, is a small, flat piece of semiconductor material (usually silicon) that contains a set of electronic circuits.

Invention: Invented by Jack Kilby and Robert Noyce, ICs have revolutionized the world of electronics.

Applications: ICs are used in devices such as computers, mobile phones, MP3 players, traffic lights, and many more.

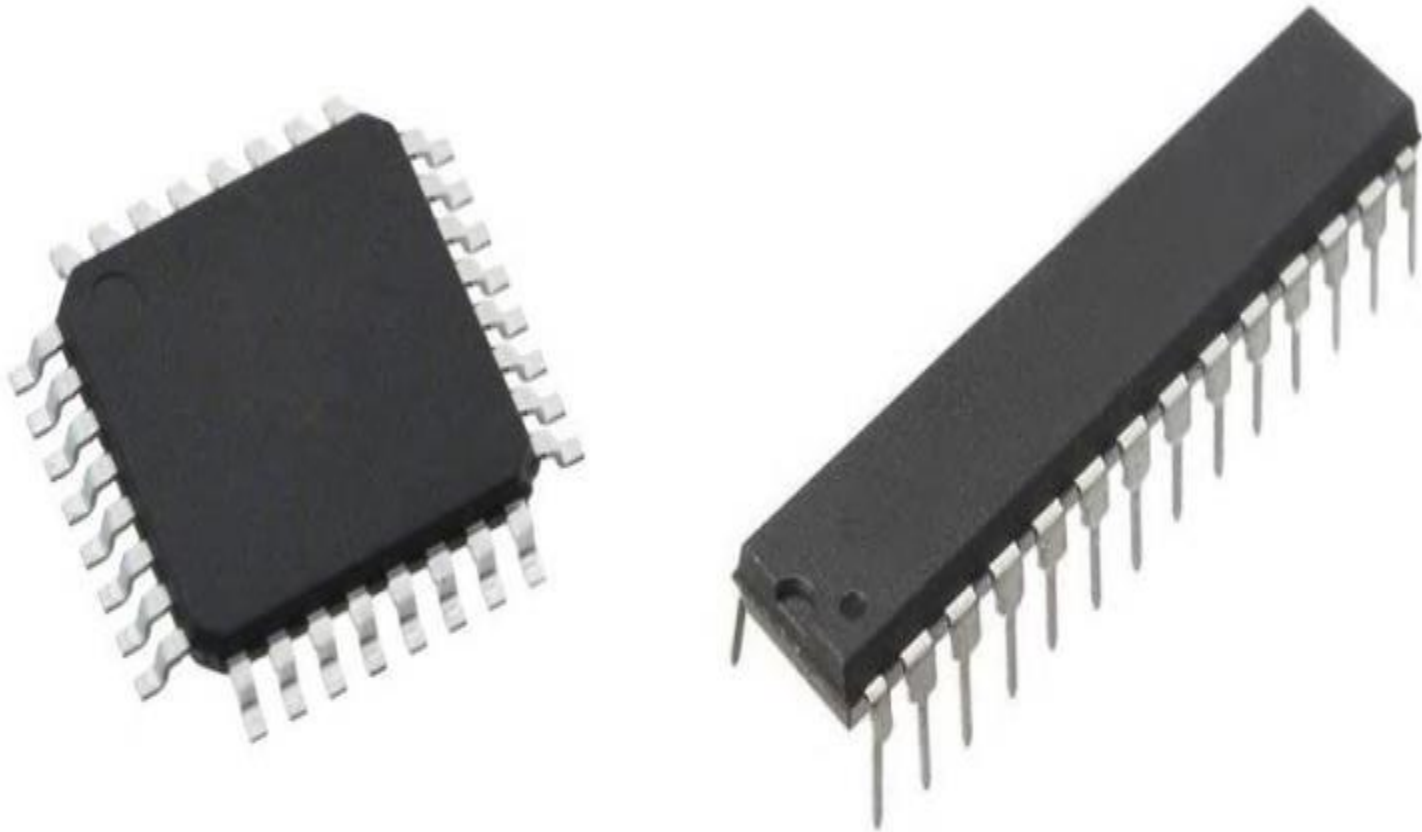

Figure: Integrated circuit.



Key Features:

- **Components:** Contains transistors, diodes, resistors, and capacitors on a single chip.
- **Small Size:** Typically around one-eighth of an inch square.
- **Power Efficiency:** Low power consumption and high speed.

Advantages:

- **Compact Size:** Reduces the overall size of electronic equipment.
- **Higher Speed:** Faster operation due to direct internal connections.
- **Cost-Effective:** Lowers production and assembly costs.



Disadvantages:

- **Current/Voltage Limits:** ICs cannot handle high currents or voltages.
- **Non-repairable:** Internal components cannot be separated for repairs.

Conclusion:

- ✓ ICs are essential for modern technology, enabling powerful, portable devices with reliable performance and cost savings.



5.6 Logic gates and logic circuits

1. Analog and Digital Signals:

Analog Signals: Continuous signals that vary smoothly over time (e.g., sinusoidal waveforms).

Digital Signals: Discrete signals representing data as sequences of 0s and 1s.

Binary Signal: Only two possible values: **0** (low voltage) and **1** (high voltage).

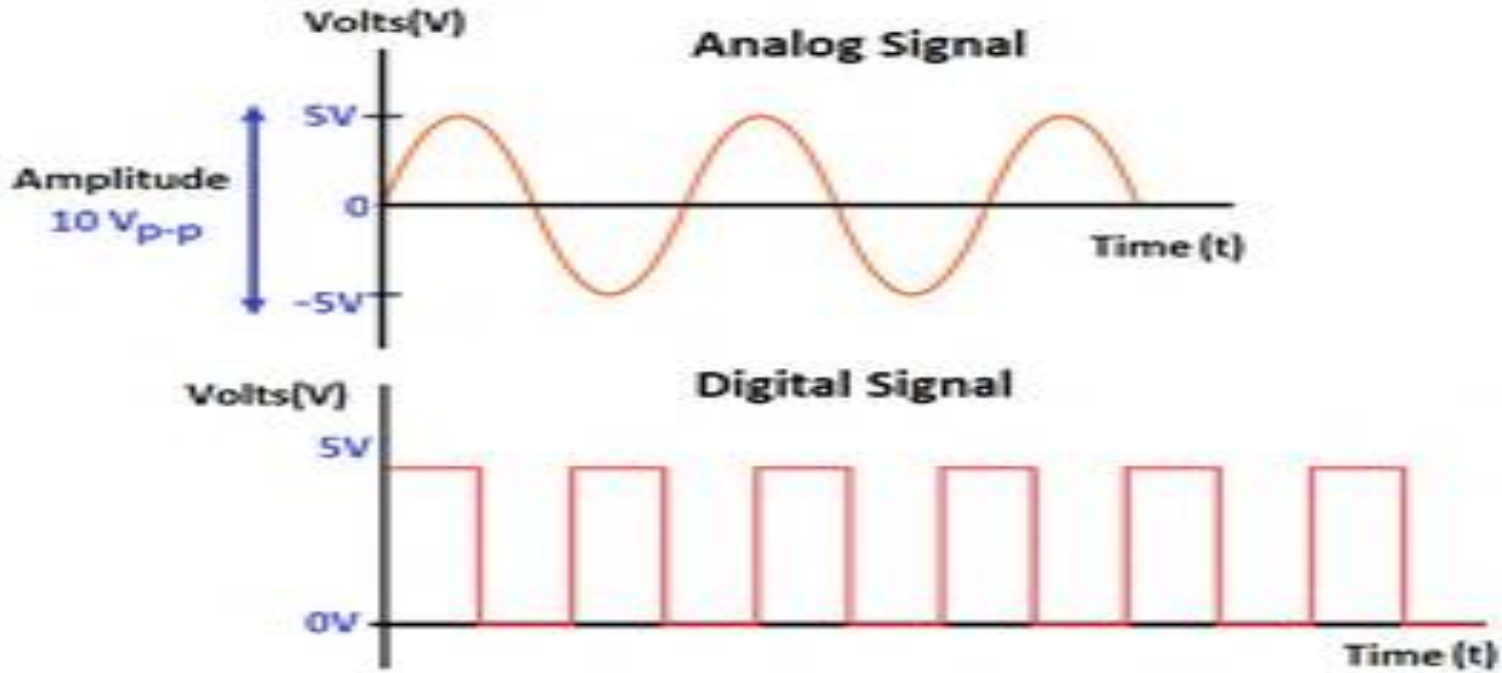

Figure : Analog and digital signals.

2. Positive and Negative Logic:

Positive Logic: 1 = High voltage (e.g., 5V), 0 = Low voltage (e.g., 0V).

Negative Logic: 1 = Low voltage, 0 = High voltage.



3. Logic Gates:

- ✓ Logic gates are the basic building blocks of digital circuits.
- ✓ They operate based on Boolean expressions.

OR Gate:

- Boolean Expression: ($y = A + B$)
- Output is 1 if either or both inputs are 1.
- **Application:** Controlling lights from two switches in a corridor.
 - ✓ *Taken as two switches in parallel.*

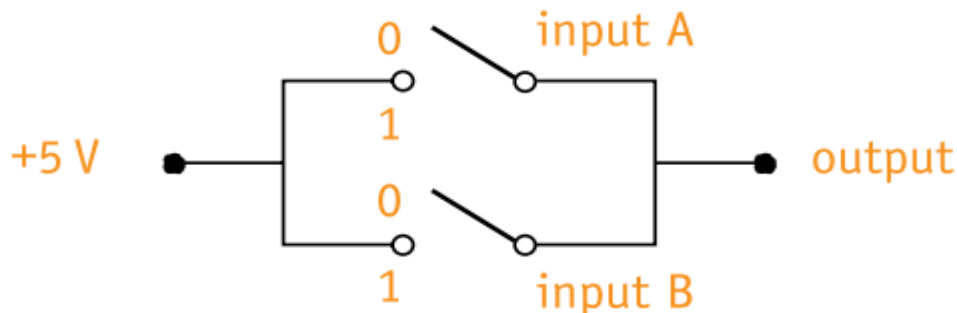

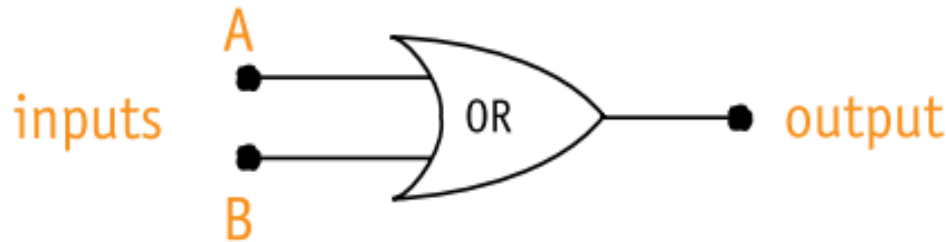

Figure: The symbol for an OR gate.

AND Gate:

- Boolean Expression: ($y = A . B$)
- Output is 1 only if both inputs are 1.
- **Application:** Indicating if both toilets in a plane are occupied.

✓ *Taken as two switches in series.*

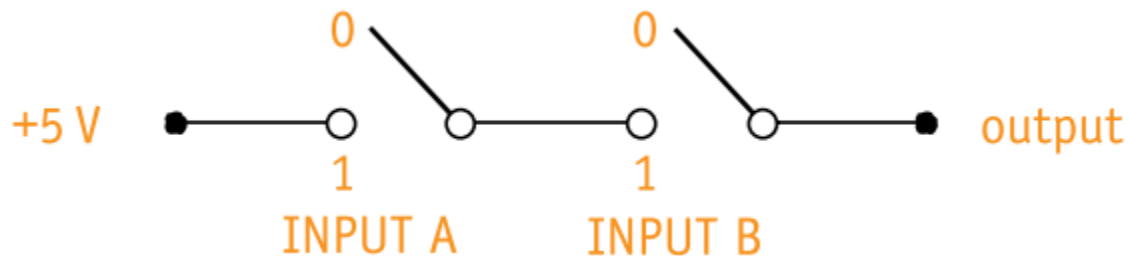



Figure : Symbol for AND gate.

NOT Gate (Inverter):

- Boolean Expression: ($y = \bar{A}$)
- Inverts the input; output is 1 if the input is 0, and vice versa.
- **Application:** Activating a water pipe when the soil is dry.

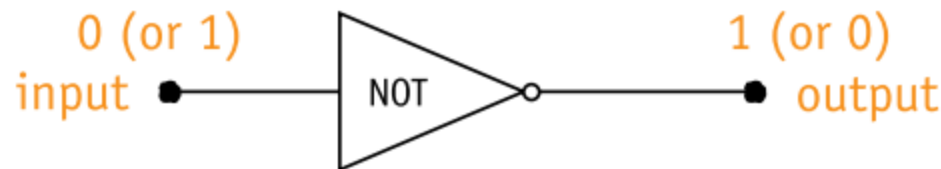

Figure : The symbol for a NOT gate.



4. Universal Logic Gates:

NAND Gate:

- Combination of an AND gate followed by a NOT gate.
- Boolean Expression: ($y = \overline{A \cdot B}$)
- Output is 1 unless both inputs are 1.

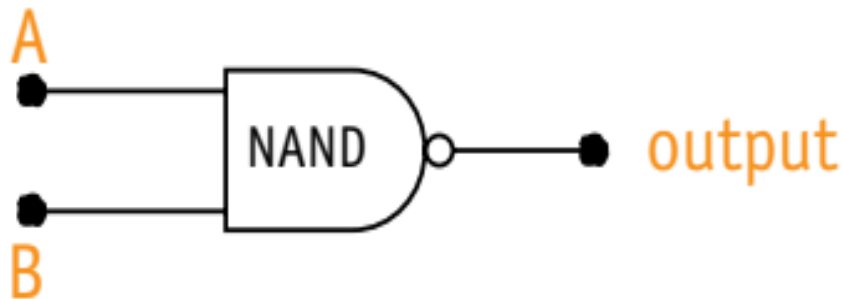

Figure : Symbol for a NAND gate.



NOR Gate:

- Combination of an OR gate followed by a NOT gate.
- Boolean Expression: $(y = \overline{A + B})$
- Output is 1 only if both inputs are 0.

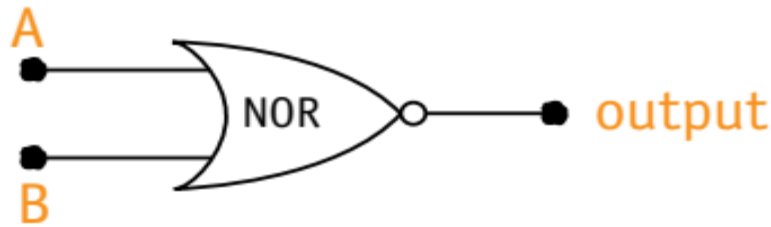

Figure : Symbol for a NOR gate.



INVERT (NOT)

Truth table

Switch analogy

Description

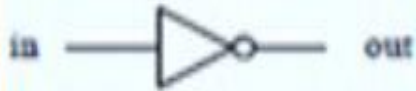

in	out
0	1
1	0

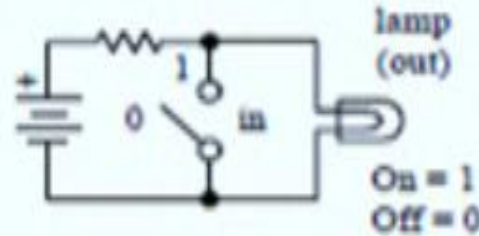

A NOT gate or *inverter* outputs a logic level that's the opposite (complement) of the input logic level.

0 = LOW voltage level
1 = HIGH voltage level

AND

A	B	out
0	0	0
0	1	0
1	0	0
1	1	1

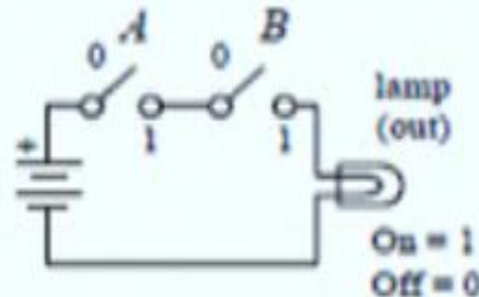

The output of an AND gate is HIGH only when both inputs are HIGH.



On = 1
Off = 0

NAND

A	B	out
0	0	1
0	1	1
1	0	1
1	1	0

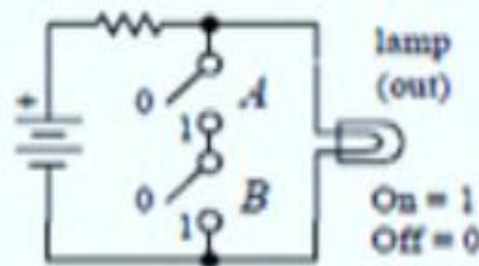

Combines the NOT function with an AND gate; output only goes LOW when both inputs are HIGH.



On = 1
Off = 0



OR



A	B	out
0	0	0
0	1	1
1	0	1
1	1	1

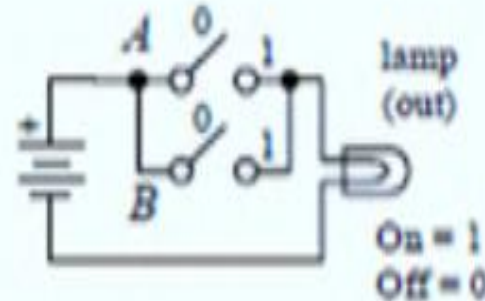

The output of an OR gate will go HIGH if one or both inputs goes HIGH. The output only goes LOW when both inputs are LOW.

NOR

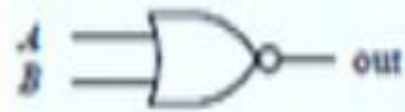

A	B	out
0	0	1
0	1	0
1	0	0
1	1	0

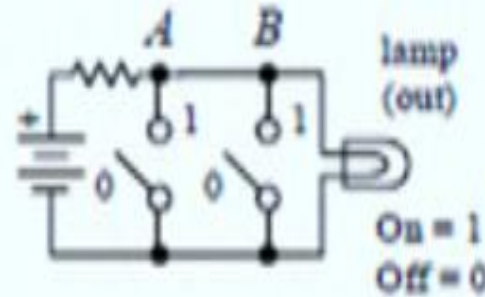

Combines the NOT function with an OR gate; output goes LOW if one or both inputs are LOW, output goes HIGH when both inputs are LOW.

Figure : A description of action of each logic gate and their corresponding switch analogy



5.7 Application of Electronics

1. Aerospace Industry

- **Applications:** Space shuttles, satellites, aircraft power management.
- **Examples:** Temperature sensors, pressure sensors, power supply systems.
- **Significance:** Essential for power management and instrument measurement.

2. Medical

- **Applications:** Diagnostic equipment, robotic surgery, advanced treatment technologies.
- **Examples:** X-rays, NMR machines, robotic check-ups, needle-free diabetes care.
- **Significance:** Enhances diagnostic capabilities and patient care.



3. Automobile

- **Applications:** Engine control, in-car entertainment, driver assistance.
- **Examples:** Carputers, active safety systems, infotainment systems.
- **Significance:** Improves engine efficiency and driving experience.

4. Utility Systems

- **Applications:** Power transmission, energy management.
- **Examples:** High voltage DC transmission, smart grids, static circuit breakers.
- **Significance:** Modernizes power distribution and efficiency.



5. Commercial

- **Applications:** Office equipment, HVAC systems, advertising.
- **Examples:** Elevators, light dimmers, uninterruptible power supplies.
- **Significance:** Enhances convenience and operational efficiency in commercial spaces.

6. Agriculture

- **Applications:** Crop monitoring, soil analysis.
- **Examples:** e-Agri sensors, moisture and nutrient sensors.
- **Significance:** Optimizes crop yield and soil management.



7. Communication

- **Applications:** Information processing and transfer.
- **Examples:** Data acquisition systems, storage devices, display units.
- **Significance:** Facilitates information exchange and management.

8. Industrial

- **Applications:** Manufacturing, automation.
- **Examples:** Industrial lasers, robotic systems, textile mills.
- **Significance:** Enhances manufacturing processes and operational efficiency.



9. Residential

- **Applications:** Household appliances and personal devices.
- **Examples:** Air conditioners, cooking appliances, personal computers.
- **Significance:** Improves daily living convenience and comfort.

10. Military

- **Applications:** Defense and surveillance.
- **Examples:** UAVs, night vision devices, infrared detectors.
- **Significance:** Supports military operations and strategic defense.



Thank you!
The End!